

XSYS

Print solid. Stay flexible.

nyloprint® **Flowline Washer DWT 100**

**Compact, tankless flowline
system for washout, drying and
post exposure**



Be
brilliant.

HIGH PRODUCTIVITY, RELIABILITY DUE TO SUPERIOR CONSTRUCTION

- **Flowline system** with optimal design for processing water washable printing plates – washout, rinsing, drying and UV-A post exposure all made automatically in line.
- **Less mechanical stress** due to a proven “push” system that prevents washing away the fine elements.
- **Water temperature indicator** and flowspeed control.
- **Direct water supply** to reduce the contamination level in the washout section, thus reducing downtime due to maintenance cleaning.
- **Automatic lowering** of squeegee roller.
- **Excellent quality** offering a long service life.

SIMPLE OPERATION AND CONVENIENT HANDLING

- **Simple operation due** to a touch screen display.
- **Single person** operating system.
- **Two easily adjustable** push carriers.
- **Runs quietly** during operation.

FURTHER COMPONENTS

- **Includes an “adhesive” carrier plate** for processing foil based plates and a “magnetic” carrier plate for steel based plates.
- **Optional brushes and a soft squeegee roller** available for special applications.

nyloprint®

Flowline Washer DWT 100

Large-size flowline combination, suitable for processing water washable printing plates up to a maximum width of 1000 mm (39.4")



Be
brilliant.

nyloprint®

Flowline Washer DWT 100

Compact, tankless flowline system for washout,
drying and post exposure

Technical data

nyloprint® Flowline Washer DWT 100

Maximum plate width	1000 mm (39.4")
Electrical connection	400 V, 50/60 Hz, 3 P/N/PE (special voltage with sep. transformer)
Nominal current	12 A
Nominal power	8 kW
Fresh water connection	R ½", 2 - 4 bar (29 - 58 PSI)
Fresh water consumption	flow rate 0.8 m ³ / h (0.47 CFM) at 30 °C (86 °F)
Waste water connection	Ø 40 mm (1.6")
Compressed air connection	G ¼", 6 bar (87 PSI), approx. 200 l/min (7.1 CFM)
Exhaust air connection	Ø 50 mm (2.0")
Exhaust air flow rate	50 Nm ³ /h (30 CFM) (approx.)
Transport speed	40 - 350 mm/min (0.13 - 1.15 ft/min)
Tube type UV-A	6 pcs., 60W TL10R
Heating capacity of dryer	6 kW
Weight (approx.)	600 kg (1323 lbs) net 1000 kg (2205 lbs) gross

Crate dimensions (W x D x H)

3300 mm x 2100 mm x 1500 mm (129.9" x 72.8" x 59.1")

Transformer for special voltage: 880 x 680 x 890 mm (34.7" x 26.8" x 35.0")

Important remark on water supply:

A temperature controlled mixing tap is required if hot and cold water is available.

An electronically controlled flow heater is required if only cold water is available.

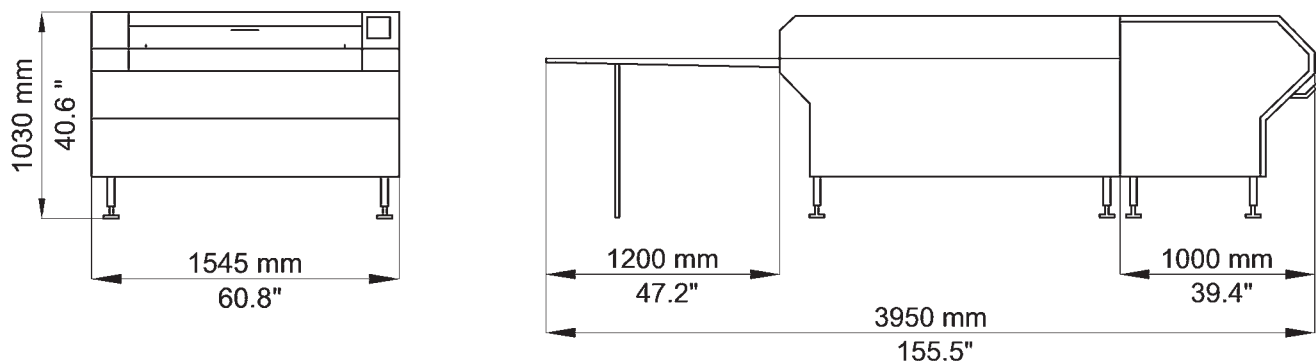

Please contact us for additional information.

info@xsyglobal.com • www.xsyglobal.com

Our technical documents are designed to inform and guide our customers. The information provided herein is accurate to the best of XSYS's knowledge; however, we accept no liability for any errors, inaccuracies, or opinions expressed. Customers are responsible for determining the suitability of this product for their specific application. XSYS assumes no responsibility for any loss incurred as a result of reliance on the information contained in this document. Product names followed by ® are registered trademarks of XSYS Germany GmbH and/or its affiliates.

XSYS 03-2025

Print solid. Stay flexible.

XSYS

Print solid. Stay flexible.