

# No solvents. No waiting. No worries.

## nyloflex® Xpress Thermal Processor FV

**New generation of thermal processing in large format  
- for great productivity with less downtime and low operating costs**

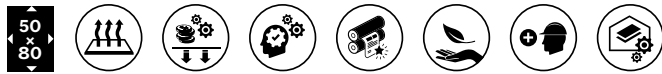
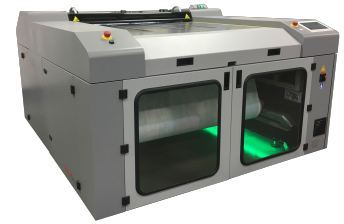

### Reduced operating costs

- + Low electricity consumption with the unique, short wave IR preheating system, cleverly designed for precise control of heating depth; no chiller or vapour handling system
- + Zoned lamps ensure maximum energy efficiency
- + Easy access to all areas for service and maintenance

### Excellent quality & improved productivity

- + Create high quality thermal plates, comparable to solvent quality, in about **1 hour** from imaging to finishing
- + Convenient front side loading and unloading of the plate and nonwovens; Jumbo nonwoven rolls allow for up to **39 full sized plates** to be processed before exchange
- + The clever design and technology incorporated keeps maintenance to an absolute minimum with normal **uptime of 99.7%** and remote diagnostics via Wi-Fi

### Sustainability and health & safety

- + Near elimination of VOCs, low energy usage, and up to **30% less fabric** in our developer rolls will substantially contribute to your sustainability efforts
- + Convenient and safe developer roll transport, loading and unloading with specialized handling lift cart

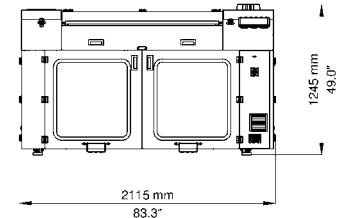
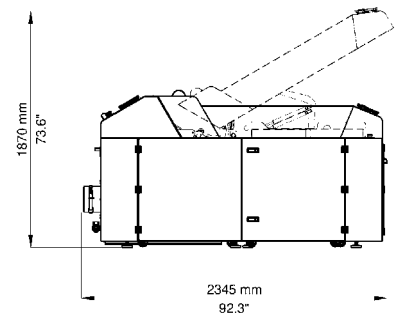

| Technical data                    | nyloflex® Xpress Thermal Processor FV                       | Art. XG50-XTP5-I101 |
|-----------------------------------|---|---------------------|
| Maximum plate size (W x L)        | 50" x 80" (1270 mm x 2032 mm)                               |                     |
| Minimum plate size (W x L)        | 32" x 12" (813 mm x 305 mm)                                 |                     |
| Plate thickness                   | 0.045" - 0.112" (1.14 mm - 2.84 mm)                         |                     |
| Electrical connection             | 230 V, 50/60 Hz (3 Ph/PE) - 26.6A                           |                     |
| Electrical connection (alternate) | 400 V, 50/60 Hz (3 Ph/N/PE) - 15.3A                         |                     |
| Nominal power                     | 10.6 kW   |                     |
| Compressed air                    | 3/8" NPT, 95 PSI, 1.2 SCFM (6.5 bar, 2.0 m <sup>3</sup> /h) |                     |
| Ethernet connection               | RJ45  |                     |
| Exhaust air                       | Ø 8" (203.2 mm), min. 600 SCFM (1019 m <sup>3</sup> /h)     |                     |
| Ambient conditions                | 65° - 80°F (18° - 27°C)                                     |                     |
| Weight (uncrated)                 | 5000 lbs (2265 kg)  |                     |
| Dimensions (W x H x L)            | 83.25" x 49" x 92.3" (2115 mm x 1245 mm x 2345 mm)          |                     |
| Weight (crated)                   | 5800 lbs (2627 kg)  |                     |
| Crate dimensions (W x H x L)      | 88" x 62" x 100" (2235 mm x 1575 mm x 2540 mm)              |                     |

Please contact us for additional information.

info@xsyglobal.com • www.xsyglobal.com

The aim of our technical documents is to inform and advise our customers. The information provided herein is correct to the best of XSYS's knowledge. No liability for any errors, facts or opinions is accepted. Customers must satisfy themselves as to the suitability of this product for their application. No responsibility for any loss as a result of any person placing reliance on any material contained herein will be accepted. Product names followed by ® are trademarks registered by XSYS Germany GmbH and/or its affiliates.

