

XSYS

Print solid. Stay flexible.

nyloflex[®] **Digital Processor FIV IP**

**Premium quality incremental
processor with pre-wash section
for digital layer separation**



Be
brilliant.

DIGITAL LAYER SEPARATION UNIT. CONSISTENT AND RELIABLE WASHOUT RESULTS

- **3D brush motion system** with servo driven motors automatically synchronizes the brush rotation and oscillation to the plate transfer speed, ensuring a constant and repeatable washout results.
- **Digital layer** separation by pre-wash section to prevent solvent contamination.
- **Constant solvent** temperature due to water circulation coil.



SOLVENT CONSUMPTION CONTROL

- **Fresh solvent** flow regulation via touch screen options.
- **Automatic viscosity** control & replenishment.
- **On-screen** component visualisation during processing.



EASY-TO-USE AND COMFORTABLE HANDLING

- **Easy-to-use rotating** and tilting touch screen to control and monitor all the operating functions.
- **Equipped with pinbar storage** for up to 8 pinbars and automatic rollaway punching.
- **Programmable automatic** solvent temperature control for optimal operation.
- **Automatic standby** after last plate processing.



nyloflex[®] Digital Processor FIV IP

Mid web format, suitable for processing high quality digital and conventional photopolymer plates up to maximum 1200 x 1600 mm (47" x 63").

Be
brilliant.

nyloflex®

Digital Processor FIV IP

**Premium quality incremental processor
with pre-wash section for digital layer separation**

Technical data	nyloflex® Digital Processor FIV IP
Maximum plate size (W x L)	1200 mm x 1600 mm (47" x 63")
Minimum plate size (W x L)	300 mm x 300 mm (11.8" x 11.8")
Plate thickness	0.7 mm - 7 mm (0.028" - 0.276")
Electrical connection	400 V, 50 / 60 Hz (3 Ph/N/PE) 230 V, 50 / 60 Hz (3 Ph/PE)
Nominal current	12 A/21 A
Nominal power	7.5 kW
Exhaust air flow rate	140 mm Ø, 600 m³/h
Compressed air	6 mm Ø min 7 bar (0.24" min 102 PSI)
Fresh solvent connection	16 mm Ø
Waste solvent connection	16 mm Ø
Weight (approx.)	2100 kg (4630 lbs) net 2690 kg (5930 lbs) gross
Crate dimensions (W x D x H)	2 crates: Processor: 3060 x 2260 x 1490 mm (120.5 x 89.0 x 58.7") Plate exit: 2580 x 2260 x 1490 mm (101.6 x 89.0 x 58.7")
Recommended ambient temp.	17 - 25 °C (63 - 77 °F)

Washout solvent

For best and consistent washout results, we recommend nylosolv® A washout solvent. If other washout solvents may be used, we advise to check it's suitability first with a XSYS technician or sales representative.

Equipment Dimensions

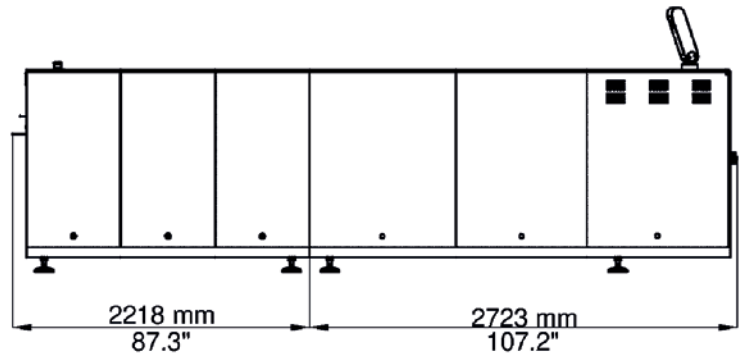
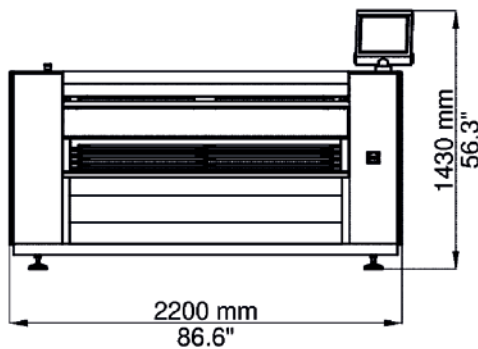

Please contact us for additional information.

info@xsyglobal.com • www.xsyglobal.com

Our technical documents are designed to inform and guide our customers. The information provided herein is accurate to the best of XSYS's knowledge; however, we accept no liability for any errors, inaccuracies, or opinions expressed. Customers are responsible for determining the suitability of this product for their specific application. XSYS assumes no responsibility for any loss incurred as a result of reliance on the information contained in this document. Product names followed by ® are registered trademarks of XSYS Germany GmbH and/or its affiliates.

XSYS 02-2025

Print solid. Stay flexible.

XSYS

Print solid. Stay flexible.